



# Product Catalog

## **Ascend™ Air-Cooled Chiller — Model ACR**

With AdaptiSpeed™ Technology

Quiet operation enabled by InvisiSound™ Technology

150 to 300 Nominal Tons



March 2019

**AC-PRC001B-EN**





# Introduction

## Overview of Design

The air-cooled chiller was designed to meet the demanding requirements of today's environment. The design transforms technology into performance on which you can depend.

Trane engineers brought innovation to every component in the next-generation Trane® chiller. The result: the high efficiency, improved system flexibility and performance, and low sound levels—all while delivering improved reliability and lower maintenance requirements.

At the core of the air-cooled chiller's performance is AdaptiSpeed™ technology—the integration of an enhanced new generation screw compressor with permanent magnet high speed motors, improved high efficiency oil flow management, and new variable volume ratio operation.

## AdaptiSpeed™ Technology

AdaptiSpeed™ technology delivers unmatched efficiency with some of the lowest sound levels in the industry.

- Variable volume ratio screw compressor—Optimized for variable-speed operation, it delivers peak efficiency under all operating conditions.
- Variable Speed, Permanent magnet motors—The compressor's and condenser fans' permanent magnet motor design is up to 4 percent more efficient than conventional induction motors.

## Copyright

This document and the information in it are the property of Trane, and may not be used or reproduced in whole or in part without written permission. Trane reserves the right to revise this publication at any time, and to make changes to its content without obligation to notify any person of such revision or change.

## Trademarks

All trademarks referenced in this document are the trademarks of their respective owners.

## Revision History

- Corrected water connection size information in general data tables.
- Updated electrical data tables.
- Updated extended unit dimensions table values.
- Updated field wiring drawing.
- Minor corrections.



# Table of Contents

Features and Benefits.....	5
Technology .....	5
Cost of Ownership .....	5
Reliability .....	5
Precision Control .....	5
Application Considerations .....	7
Water Treatment.....	7
Effect of Altitude on Capacity .....	7
Ambient Limitations .....	7
Water Flow Limits.....	7
Water Temperature .....	8
Variable Flow in the Evaporator .....	9
Series Chiller Arrangements.....	9
Typical Water Piping .....	10
Multiple Unit Operation .....	10
Ice Storage Operation.....	11
Unit Placement .....	11
Unit Location .....	12
Model Number Descriptions.....	14
Unit Model Number.....	14
General Information .....	16
General Data .....	16
Unit Length .....	17
Controls .....	18
Tracer UC800 Controller.....	18
Tracer AdaptiView TD7 Operator Interface .....	18
System Integration.....	19
Building Automation and Chiller Plant Control .....	20
Integrated Comfort System (ICS).....	21
Electrical.....	22
Electrical Data .....	22
Customer Wiring .....	25
Electrical Connections .....	28



## Table of Contents

---

Dimensions and Weights .....	30
Weights.....	30
Service Clearance.....	31
Unit Dimensions.....	32
Mechanical Specifications .....	36
General .....	36
Certified AHRI Performance.....	36
Refrigeration Circuits.....	36
Evaporator .....	36
Condenser and Fans .....	36
Compressor and Lube Oil System .....	37
Drive Cooling System .....	37
Unit Controls .....	37
Adaptive Frequency Drive .....	38
Chilled Water Reset .....	38
Factory Mounted Flow Proving and Flow Control .....	38
Options .....	39
Application Options.....	39
Electrical Options .....	39
Control Options.....	39
Sound Options .....	40
Other Options .....	40



# Features and Benefits

## Technology

- AdaptiSpeed™ technology assures optimal performance at all operating conditions
  - Permanent magnet motor - up to 4% more efficient than an induction motor
  - AFD Adaptive Frequency™ Drive
    - Soft start provided as standard to reduce power in-rush at start-up
    - Available with Passive Harmonic Filtering achieving 5% TDD (optional)
  - Variable volume ratio compressor design optimized for efficiency at all load conditions
  - Rotor profile designed for maximum efficiency at higher speeds
- Shuttle valve enhances compressor oil management
- Variable speed permanent magnet motors on ALL condenser fans for increased efficiency and lower sound
- Larger diameter condenser fans operate at lower speed with optimized blade design
- Compact, high-efficiency, integrated low refrigerant charge evaporator design
- Integral compressor muffler lowers sound levels by 4-10 dB compared to previous design
- Optional metallic discharge and suction bellows reduce compressor sound by 8-10 dB

## Cost of Ownership

- Industry-leading efficiency
  - Over 18% better full load efficiency than ASHRAE 90.1-2016 Path B
    - Minimizing kW demand and infrastructure
  - Over 22% higher IPLV than ASHRAE 90.1-2016 Path B
    - Minimizing kW usage
- High power factor at all load points reducing the need for power factor correction capacitors
- Variable speed drives on all condenser fans save energy at part load operation, as well as lower sound levels even further as fan speeds are reduced during part load operation.
- Transverse modular coil design for easy access for coil cleaning
- Up to 40% lower refrigerant charge compared to previous evaporator designs
- Factory-engineered, tested and installed sound control options reduce jobsite time and cost
- Three levels of sound reduction available to meet various job site acoustical requirements

## Reliability

- Industrial bearing system designed for the life of the chiller
- Shuttle valve reduces the differential oil pressure required for cold weather start-up
- Design eliminates brazed coil u-bends, significantly reduces potential for refrigerant leaks
- All aluminum alloy coils reduce potential for corrosion
- Enhanced factory-applied corrosion protection available
- Rapid Restart capability minimizes downtime

## Precision Control

- 7-inch color touch screen display with graphics
- Powered by UC800 industry-leading control algorithms — Enhanced flow management provides unmatched system performance in variable flow water systems
- Adaptive Control™ keeps the chiller running in extreme conditions



## Features and Benefits

---

- Tight set point control
- Graphical trending
- Maximized chiller update
- BACnet®, Modbus™, LonTalk®, communications protocol interface available without the need for gateways
- Optional condenser fan speed control to help meet preset nighttime sound requirements



## Application Considerations

Certain application constraints should be considered when sizing, selecting, and installing Trane chillers. Unit and system reliability is often dependent on properly and completely complying with these considerations. When the application varies from the guidelines presented, it should be reviewed with your local sales engineer.

**Note:** *The terms water and solution are used interchangeably in the following paragraphs.*

### Water Treatment

The use of untreated or improperly treated water may result in scaling, erosion, corrosion, and algae or slime buildup. This will adversely affect heat transfer between the water and system components. Proper water treatment must be determined locally and depends on the type of system and local water characteristics.

Neither salt nor brackish water is recommended for use in Trane air-cooled chillers. Use of either will lead to a shortened life. Trane encourages the employment of a qualified water treatment specialist, familiar with local water conditions, to assist in the establishment of a proper water treatment program.

Foreign matter in the chilled water system can also increase pressure drop and, consequently, reduce water flow. For this reason it is important to thoroughly flush all water piping to the unit before making the final piping connections to the unit.

### Effect of Altitude on Capacity

At elevations substantially above sea level, the decreased air density will decrease condenser capacity and, therefore, unit capacity and efficiency.

### Ambient Limitations

Trane chillers are designed for year-round operation over a range of ambient temperatures.

- Standard Ambient Range = 32 to 105°F (0 to 40.6°C)
- Low Ambient Range = 0 to 105°F (-17.7 to 40.6°C)
- Extreme Low Ambient Range = -20 to 105°F (-28.9 to 40.6°C)
- High Ambient Range = 32 to 125°F (0 to 52°C)
- Wide Ambient Range = 0 to 125°F (-17.7 to 52°C)

The minimum ambient temperatures are based on still conditions (winds not exceeding five mph). Greater wind speeds will result in a drop in head pressure, therefore increasing the minimum starting and operating ambient temperature. The AdaptiveFrequency™ microprocessor will attempt to keep the chiller on-line when high or low ambient conditions exist, making every effort to avoid nuisance trip-outs and provide the maximum allowable tonnage.

### Water Flow Limits

The minimum water flow rates are given in the General Data chapter of this catalog. Evaporator flow rates below the tabulated values will result in laminar flow causing freeze-up problems, scaling, stratification and poor control.

The maximum evaporator water flow rate is also given in General Data. Flow rates exceeding those listed may result in very high pressure drop across the evaporator and/or excessive tube erosion.

**Note:** *Flow rates in the general data tables are for water only. They do not include freeze inhibitors.*

## Flow Rates Out of Range

Many process cooling jobs require flow rates that cannot be met with the minimum and maximum published values within the evaporator. A simple piping change can alleviate this problem. For example: a plastic injection molding process requires 80 gpm (5.0 l/s) of 50°F (10°C) water and returns that water at 60°F (15.6°C). The selected chiller can operate at these temperatures, but has a minimum flow rate of 106 gpm (6.6 l/s). The system layout in the figure below can satisfy the process.

**Figure 1. Flow rate out of range systems solution**

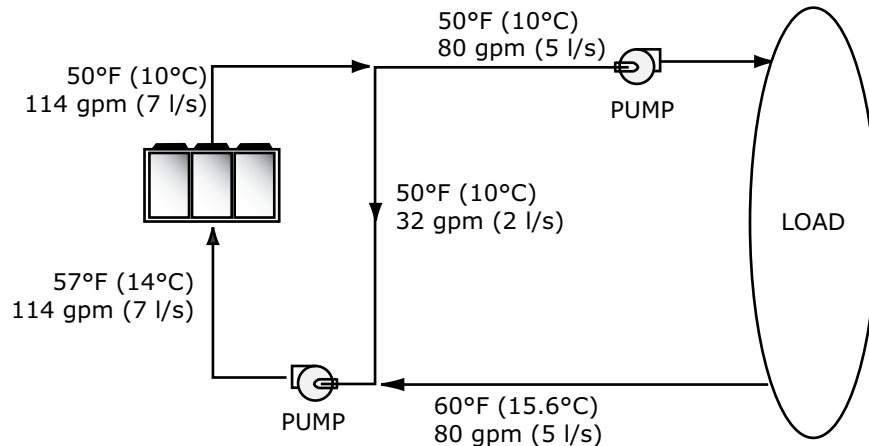

### Flow Proving

Trane provides a factory-installed water flow switch monitored by UC800 which protects the chiller from operating in loss of flow conditions.

## Water Temperature

### Leaving Water Temperature Limits

Trane chillers have distinct leaving water categories:

- Standard, with a leaving solution range of 40 to 68 (4.4 to 20°C)
- Low temperature process cooling, with leaving solution less than 40°F (4.4°C)
- Ice-making, with a leaving solution range of 20 to 68°F (-6.7 to 20°C)

Since leaving solution temperatures below 40°F (4.4°C) result in suction temperature at or below the freezing point of water, a glycol solution is required for all low temperature and ice-making machines. Ice making control includes dual setpoints and safeties for ice making and standard cooling capabilities. Consult your local Trane account manager for applications or selections involving low temperature or ice making machines.

The maximum water temperature that can be circulated through the evaporator when the unit is not operating is 125°F (52°C). Evaporator damage may result above this temperature.

### Leaving Water Temperature Out of Range

Many process cooling jobs require temperature ranges that cannot be met with the minimum and maximum published values for the chiller. A simple piping change can alleviate this problem. For example, a laboratory load requires 238 gpm (15 l/s) of water entering the process at 86°F (30°C) and returning at 95°F (35°C). The chiller's maximum leaving chilled water temperature of 68°F (20°C) prevents direct supply to the load. In the example shown, both the chiller and process flow rates are equal, however, this is not necessary. For example, if the chiller had a higher flow rate, there would be more water bypassing and mixing with warm water returning to the chiller.

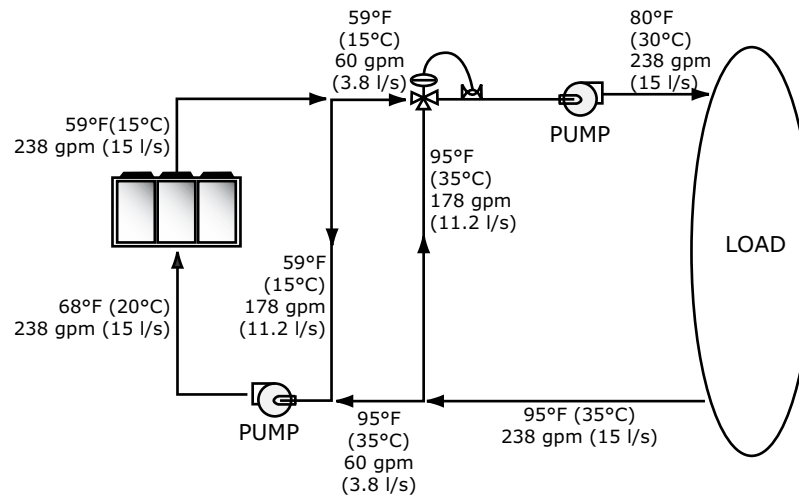

**Figure 2. Temperature out of range system solution**

## Variable Flow in the Evaporator

An attractive chilled water system option may be a variable primary flow (VPF) system. VPF systems present building owners with several cost saving benefits that are directly related to the pumps. The most obvious cost savings result from eliminating the secondary distribution pump, which in turn avoids the expense incurred with the associated piping connections (material, labor), electrical service, and variable frequency drive. Building owners often cite pump related energy savings as the reason that prompted them to install a VPF system.

The evaporator on the chiller can withstand up to 50 percent water flow reduction as long as this flow is equal to or above the minimum flow rate requirements. The microprocessor and capacity control algorithms are designed to handle a maximum of 10% change in water flow rate per minute in order to maintain  $\pm 0.5^\circ\text{F}$  ( $0.28^\circ\text{C}$ ) leaving evaporator temperature control. For applications in which system energy savings is most important and tight temperature control is classified as  $\pm 2^\circ\text{F}$  ( $1.1^\circ\text{C}$ ), up to 30 percent changes in flow per minute are possible.

With the help of a software analysis tool such as System Analyzer™, DOE-2 or TRACE™, you can determine whether the anticipated energy savings justify the use of variable primary flow in a particular application. It may also be easier to apply variable primary flow in an existing chilled water plant. Unlike the "decoupled" system design, the bypass can be positioned at various points in the chilled water loop and an additional pump is unnecessary.

## Series Chiller Arrangements

Another energy saving strategy is to design the system around chillers arranged in series. The actual savings possible with such strategies depends on the application dynamics and should be researched by consulting your Trane® Systems Solutions Representative and applying an analysis tool from the Trace software family. It is possible to operate a pair of chillers more efficiently in a series chiller arrangement than in a parallel arrangement. It is also possible to achieve higher entering to leaving chiller differentials, which may, in turn, provide the opportunity for lower chilled water design temperature, lower design flow, and resulting installation and operational cost savings. The Trane screw compressor also has excellent capabilities for "lift," which affords an opportunity for "lift," which affords an opportunity for savings on the evaporator water loop.

Series chiller arrangements can be controlled in several ways. The figure below shows a strategy where each chiller is trying to achieve the system design set point. If the cooling load is less than 50 percent of the systems capabilities, either chiller can fulfill the demand. As system loads increase, the Chiller 2 becomes preferentially loaded as it attempts to meet the leaving chilled water setpoint. Chiller 1 will finish cooling the leaving water from Chiller 2 down to the system design setpoint.

Staggering the chiller set points is another control technique that works well for preferentially loading Chiller 1. If the cooling load is less than 50 percent of the system capacity, Chiller 1 would be able to satisfy the entire call for cooling. As system loads increase, Chiller 2 is started to meet any portion of the load that Chiller 1 can not meet.

**Figure 3. Typical series chiller arrangement**

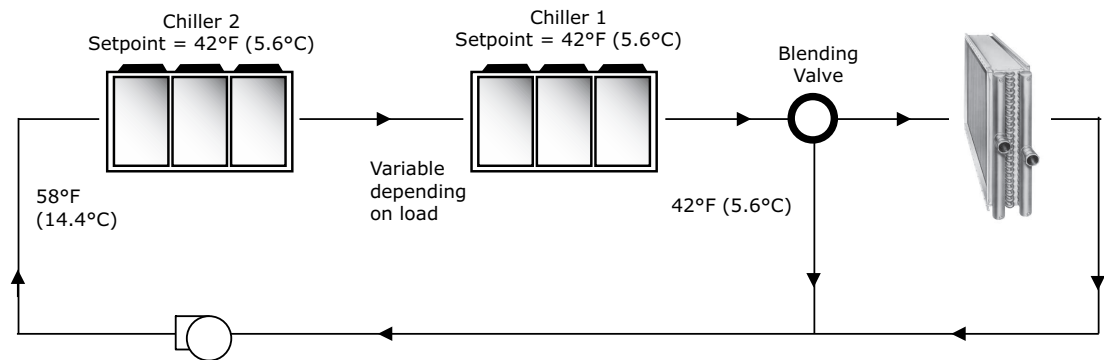

## Typical Water Piping

All building water piping must be flushed prior to making final connections to the chiller. To reduce heat loss and prevent condensation, insulation should be applied. Expansion tanks are also usually required so that chilled water volume changes can be accommodated.

## Avoidance of Short Water Loops

Adequate chilled water system water volume is an important system design parameter because it provides for stable chilled water temperature control and helps limit unacceptable short cycling of chiller compressors.

The chiller's temperature control sensor is located in the waterbox. This location allows the building to act as a buffer to slow the rate of change of the system water temperature. If there is not a sufficient volume of water in the system to provide an adequate buffer, temperature control can suffer, resulting in erratic system operation and excessive compressor cycling.

Typically, a two-minute water loop circulation time is sufficient to prevent short water loop issues. Therefore, as a guideline, ensure the volume of water in the chilled water loop equals or exceeds two times the evaporator flow rate. For systems with a rapidly changing load profile the amount of volume should be increased.

If the installed system volume does not meet the above recommendations, the following items should be given careful consideration to increase the volume of water in the system and, therefore, reduce the rate of change of the return water temperature.

- A volume buffer tank located in the return water piping.
- Larger system supply and return header piping (which also reduces system pressure drop and pump energy use).

## Minimum Water Volume for a Process Application

If a chiller is attached to an on/off load such as a process load, it may be difficult for the controller to respond quickly enough to the very rapid change in return solution temperature if the system has only the minimum water volume recommended. Such systems may cause chiller low temperature safety trips or in the extreme case evaporator freezing. In this case, it may be necessary to add or increase the size of the mixing tank in the return line.

## Multiple Unit Operation

Whenever two or more units are used on one chilled water loop, Trane recommends that their operation be coordinated with a higher level system controller for optimum system efficiency and reliability. The Trane Tracer® system has advanced chilled plant control capabilities designed to provide such operation.

## Ice Storage Operation

An ice storage system uses the chiller to make ice at night when utilities generate electricity more efficiently with lower demand and energy charges. The stored ice reduces or even replaces mechanical cooling during the day when utility rates are at their highest. This reduced need for cooling results in significant utility cost savings and source energy savings.

Another advantage of an ice storage system is its ability to eliminate chiller over sizing. A “right-sized” chiller plant with ice storage operates more efficiently with smaller support equipment while lowering the connected load and reducing operating costs. Best of all, this system still provides a capacity safety factor and redundancy by building it into the ice storage capacity for practically no cost compared to oversized systems.

Trane air-cooled chillers are uniquely suited to low temperature applications like ice storage because of the ambient relief experienced at night. Chiller ice making efficiencies are typically similar to or even better than standard cooling daytime efficiencies as a result of night-time dry-bulb ambient relief.

Standard smart control strategies for ice storage systems are another advantage of the chiller. The dual mode control functionality is integrated right into the chiller. Trane Tracer® building management systems can measure demand and receive pricing signals from the utility and decide when to use the stored cooling and when to use the chiller.

## Unit Placement

### Setting The Unit

A base or foundation is not required if the selected unit location is level and strong enough to support the unit’s operating weights shown in Weights chapter.

For a detailed discussion of base and foundation construction, see the unit Installation, Operation or Maintenance (IOM) manual. Manuals are available through online product portal pages or from your local office.

HVAC equipment must be located to minimize sound and vibration transmission to the occupied spaces of the building structure it serves. If the equipment must be located in close proximity to a building, it should be placed next to an unoccupied space such as a storage room, mechanical room, etc. It is not recommended to locate the equipment near occupied, sound sensitive areas of the building or near windows. Locating the equipment away from structures will also prevent sound reflection, which can increase sound levels at property lines or other sensitive points.

### Isolation and Sound Emission

Structurally transmitted sound can be reduced by elastomeric vibration eliminators. Elastomeric isolators are generally effective in reducing vibratory noise generated by compressors, and therefore, are recommended for sound sensitive installations. An acoustical engineer should always be consulted on critical applications.

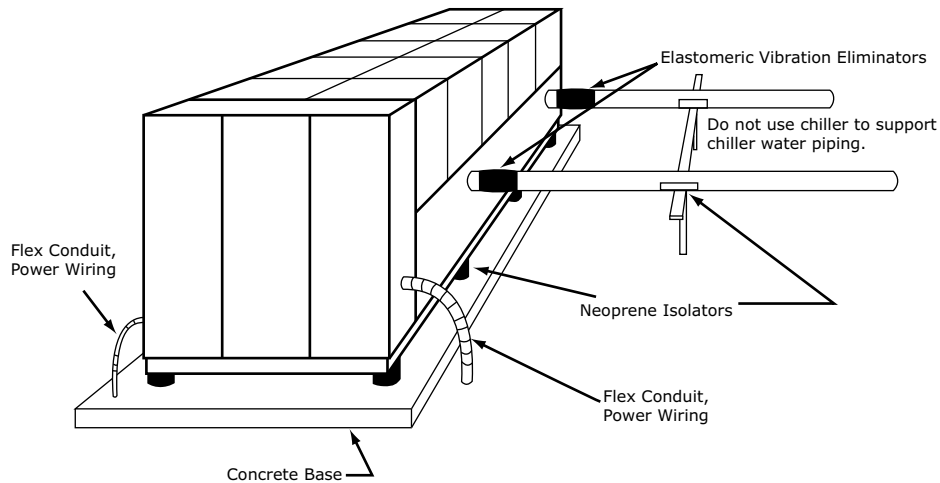
**Figure 4. Installation example**

For maximum isolation effect, water lines and electrical conduit should also be isolated. Wall sleeves and rubber isolated piping hangers can be used to reduce sound transmitted through water piping. To reduce the sound transmitted through electrical conduit, use flexible electrical conduit.

Local codes on sound emissions should always be considered. Since the environment in which a sound source is located affects sound pressure, unit placement must be carefully evaluated. Sound power levels for chillers are available on request.

## Servicing

Adequate clearance for evaporator, condenser and compressor servicing should be provided. Recommended minimum space envelopes for servicing are located in the dimensional data section and can serve as a guideline for providing adequate clearance. The minimum space envelopes also allow for control panel door swing and routine maintenance requirements. Local code requirements may take precedence.

## Unit Location

### General

Unobstructed flow of condenser air is essential to maintain chiller capacity and operating efficiency. When determining unit placement, careful consideration must be given to assure a sufficient flow of air across the condenser heat transfer surface. Two detrimental conditions are possible and must be avoided: warm air recirculation and coil starvation. Air recirculation occurs when discharge air from the condenser fans is recycled back to the condenser coil inlet. Coil starvation occurs when free airflow to the condenser is restricted.

Condenser coils and fan discharge must be kept free of snow or other obstructions to permit adequate airflow for satisfactory unit operation. Debris, trash, supplies, etc., should not be allowed to accumulate in the vicinity of the air-cooled chiller. Supply air movement may draw debris into the condenser coil, blocking spaces between coil fins and causing coil starvation.

Both warm air recirculation and coil starvation cause reductions in unit efficiency and capacity due to higher head pressures. The air-cooled chiller offers an advantage over competitive equipment in these situations. Operation is minimally affected in many restricted air flow situations due to its advanced Adaptive Control™ microprocessor which has the ability to understand the operating environment of the chiller and adapt to it by first optimizing its performance and then staying on line through abnormal conditions. For example, high ambient temperatures combined with a restricted air flow situation will generally not cause the air-cooled chiller to shut down. Other chillers would typically shut down on a high pressure nuisance cut-out in these conditions.

Cross winds, those perpendicular to the condenser, tend to aid efficient operation in warmer ambient conditions. However, they tend to be detrimental to operation in lower ambients due to the accompanying loss of adequate head pressure. Special consideration should be given to low ambient units. As a result, it is advisable to protect air-cooled chillers from continuous direct winds exceeding 10 mph (4.5 m/s) in low ambient conditions.

The recommended lateral clearances are depicted in the close spacing engineering bulletin available from your local office.

### **Provide Sufficient Unit-to-Unit Clearance**

Units should be separated from each other by sufficient distance to prevent warm air recirculation or coil starvation. Doubling the recommended single unit air-cooled chiller clearances will generally prove to be adequate. See Close-Spacing and Restricted Airflow Engineering Bulletin AC-PRB001\*-EN for more information.

### **Walled Enclosure Installations**

When the unit is placed in an enclosure or small depression, the top of the surrounding walls should be no higher than the top of the fans. The chiller should be completely open above the fan deck. There should be no roof or structure covering the top of the chiller. Ducting individual fans is not recommended. See Close-Spacing and Restricted Airflow Engineering Bulletin AC-PRB001\*-EN for more information.



# Model Number Descriptions

## Unit Model Number

### Digit 1, 2, 3, 4 — Unit Model

**ACRA** = Air-Cooled Screw Chiller

### Digit 5, 6, 7 — Nominal Tonnage

**150** = 150 Tons  
**165** = 165 Tons  
**180** = 180 Tons  
**200** = 200 Tons  
**225** = 225 Tons  
**250** = 250 Tons  
**275** = 275 Tons  
**300** = 300 Tons

### Digit 8 — Unit Voltage

**A** = 200/60/3  
**B** = 230/50/3  
**C** = 380/50/3  
**D** = 380/60/3  
**E** = 400/50/3  
**F** = 460/60/3  
**G** = 575/60/3  
**H** = 400/60/3

### Digit 9 — Manufacturing Location

**U** = Trane Commercial Systems, Pueblo, CO USA

### Digits 10, 11 — Design Sequence

\*\* = Factory assigned

### Digit 12 — Unit Sound Package

**1** = InvisiSound™ Standard Unit  
**2** = InvisiSound™ Superior (Line Wraps, Reduced Fan Speed)  
**3** = InvisiSound™ Ultimate (Compressor Sound Attenuation, Line Wraps, Reduced Fan Speed)

### Digit 13 — Agency Listing

**0** = No Agency Listing  
**A** = UL/cUL Listing

### Digit 14 — Pressure Vessel Code

**A** = ASME Pressure Vessel Code  
**C** = CRN or Canadian Equivalent Pressure Vessel Code  
**D** = Australia Pressure Vessel Code

### Digit 15 — Factory Charge

**1** = Refrigerant Charge R-134a  
**2** = Nitrogen Charge

### Digit 16 — Evaporator Application

**F** = Standard Cooling (40 to 65°F/5.5 to 18°C)  
**G** = Low Temp Process Cooling (below 40°F/5.5°C)  
**C** = Ice Making (20 to 6°F/7 to 18°C) with Hardwired Interface

### Digit 17 — Evaporator Configuration

**N** = 2-pass Evaporator  
**P** = 3-pass Evaporator

### Digit 18 — Evaporator Fluid Type

**1** = Water  
**2** = Calcium Chloride  
**3** = Ethylene Glycol  
**4** = Propylene Glycol  
**5** = Methanol

### Digit 19 — Water Connection

**X** = Grooved Pipe  
**F** = Grooved Pipe + Flange

### Digit 20 — Flow Switch

**1** = Factory Installed - Other Fluid (15 cm/s)  
**2** = Factory Installed - Water 2 (35 cm/s)  
**3** = Factory Installed - Water 3 (45 cm/s)

### Digit 21 — Insulation

**A** = Factory Insulation — All Cold Parts 0.75"  
**B** = Evaporator-only Insulation for High Humidity/Low Evap Temp 1.25"

### Digit 22 — Unit Application

**1** = Standard Ambient (32 to 105°F/0 to 40.6°C)  
**2** = Low Ambient (0 to 105°F/-17.7 to 40.6°C)  
**3** = Extreme Low Ambient (-20 to 105°F/-28.9 to 40.6°C)  
**4** = High Ambient (32 to 125°F/0 to 52°C)  
**5** = Wide Ambient (0 to 125°F/-17.7 to 52°C)

### Digit 23 — Condenser Fin Options

**A** = Aluminum Fins with Slits  
**D** = CompleteCoat™ Epoxy Coated Fins

### Digit 24, 25 — Not Used

**00** = Reserved for future use

### Digit 26 — Power Line Connection Type

**A** = Terminal Block  
**C** = Circuit Breaker  
**D** = Circuit Breaker with High Fault Rated Control Panel

### Digit 27 — Short Circuit Current Rating

**A** = Default A Short Circuit Rating  
**B** = High A Short Circuit Rating

### Digit 28 — Transformer

**0** = No Transformer  
**1** = Factory Installed Transformer

### Digit 29 — Line Voltage Harmonic Mitigation

**X** = DC Reactors (~30% TDD)  
**1** = Filter circuit (IEEE519 Compliant)

### Digit 30 — Electrical Accessories

**0** = No Convenience Outlet  
**C** = 15A 115V Convenience Outlet (Type B)

### Digit 31 — Remote Communication Option

**0** = None  
**1** = LonTalk® Interface (LCI-C)  
**2** = BACnet® MS/TP Interface  
**3** = Modbus™ Interface

### Digit 32 — Hard Wire Communication

**X** = None  
**A** = Hard Wired Bundle - All  
**B** = Remote Leaving Water Temp Setpoint  
**C** = Remote Leaving Temp and Demand Limit Setpoints  
**D** = Programmable Relay  
**E** = Programmable Relay and Leaving Water and Demand Limit Setpoint  
**F** = Percent Capacity  
**G** = Percent Capacity and Leaving Water and Demand Limit Setpoint  
**H** = Percent Capacity and Programmable Relay

**Digit 33 – Not Used**

**A** = Reserved for future use

**Digit 34 – Structural Options**

**A** = Standard Unit Structure

**Digit 35 – Appearance Accessories**

**0** = No Appearance Options

**A** = Architectural Louvered Panels

**Digit 36 – Unit Isolation**

**0** = None

**1** = Elastomeric Isolators

**Digit 37, 38 – Not Used**

**00** = Reserved for future use

**Digit 39 – Special**

**0** = None

**S** = Special

**F** = Ship to Final Finisher



# General Information

## General Data

Table 1. General data table

Unit Size (tons)		150	165	180	200	225	250	275	300
Compressor Model		CHHSR	CHHSR	CHHSR	CHHSR	CHHSS	CHHSS	CHHSS	CHHSS
Quantity	#	2	2	2	2	2	2	2	2
<b>Evaporator</b>									
Water Storage	(gal)	17.5	18.7	21.9	23.9	26.6	28.7	33.0	36.0
	(L)	66.1	70.9	82.8	90.5	100.6	108.8	125.0	136.1
2 Pass arrangement									
Water Connection Size	(in)	5	5	6	6	6	6	8	8
	(mm)	125	125	150	150	150	150	200	200
Minimum Flow	(gpm)	171	187	202	228	261	288	318	354
	(l/s)	10.8	11.8	12.7	14.4	16.5	18.2	20.1	22.3
Maximum Flow	(gpm)	626	684	742	835	957	1055	1165	1299
	(l/s)	39.5	43.1	46.8	52.7	60.4	66.5	73.5	81.9
3 Pass arrangement									
Water Connection Size	(in)	4	4	5	5	5	5	6	6
	(mm)	100	100	125	125	125	125	150	150
Minimum Flow	(gpm)	114	124	135	152	174	192	212	236
	(l/s)	7.2	7.8	8.5	9.6	11.0	12.1	13.4	14.9
Maximum Flow	(gpm)	417	456	495	557	638	703	777	866
	(l/s)	26.3	28.8	31.2	35.1	40.2	44.3	49.0	54.6
<b>Condenser</b>									
Qty of Coils		8	10	10	12	12	12	14	16
Coil Length	(in)	78.74	78.74	78.74	78.74	78.74	78.74	78.74	78.74
	(mm)	2000	2000	2000	2000	2000	2000	2000	2000
Coil Height	(in)	50	50	50	50	50	50	50	50
	(mm)	1270	1270	1270	1270	1270	1270	1270	1270
Fins/Ft		192	192	192	192	192	192	192	192
Rows		3	3	3	3	3	3	3	3
<b>Condenser Fans</b>									
Quantity	#	8	10	10	12	12	12	14	16
Diameter	(in)	37.5	37.5	37.5	37.5	37.5	37.5	37.5	37.5
	(mm)	953	953	953	953	953	953	953	953
Total Airflow	(cfm)	107,392	134,240	134,240	161,088	161,088	161,088	187,936	214,784
	(m <sup>3</sup> /hr)	182,460	228,075	228,075	273,690	273,690	273,690	319,305	364,920



**Table 1. General data table (continued)**

<b>Unit Size (tons)</b>		<b>150</b>	<b>165</b>	<b>180</b>	<b>200</b>	<b>225</b>	<b>250</b>	<b>275</b>	<b>300</b>
Tip Speed	(ft/min)	8700	8700	8700	8700	8700	8700	8700	8700
	(M/S)	44.2	44.2	44.2	44.2	44.2	44.2	44.2	44.2
<b>Ambient Temperature Range</b>									
Standard Ambient	°F (°C)	32 to 105 (0 to 40.6)							
Low Ambient	°F (°C)	0 to 105 (-17.7 to 40.6)							
Extreme Low Ambient	°F (°C)	-20 to 105 (-28.9 to 40.6)							
High Ambient	°F (°C)	32 to 125 (0 to 52)							
Wide Ambient	°F (°C)	0 to 125 (-17.7 to 52)							
<b>General Unit</b>									
Refrigerant		HFC-134a							
Refrigerant Ckts	#	2							
Minimum Load	%	20	18	17	15	20	18	16	15
Refrigerant Charge/ckt	(lbs)	172	181	210	218	265	261	318	325
	(kg)	78	82	95	99	120	118	144	148
Oil		Trane OIL00311							
Oil Charge/ckt	(gal)	3.0	3.0	3.0	3.0	4.0	4.0	4.0	4.0
	(L)	11.4	11.4	11.4	11.4	15.1	15.1	15.1	15.1

## Unit Length

Units are EXTENDED length if either of the following are selected:

- Transformer: Model number digit 28 = 1
- Harmonic Filtration Option: Model number digit 29 = 1

Units without Harmonic Filtration Option or Transformer (digits 28, 29 = 0X) are STANDARD length.



# Controls

## Tracer UC800 Controller

Trane chillers offer predictive controls that anticipate and compensate for load changes. Other control strategies made possible with the Tracer® UC800 controls are:

### Feedforward Adaptive Control

Feedforward is an open-loop, predictive control strategy designed to anticipate and compensate for load changes. It uses evaporator entering-water temperature as an indication of load change. This allows the controller to respond faster and maintain stable leaving-water temperatures.

### Soft Loading

The chiller controller uses soft loading except during manual operation. Large adjustments due to load or setpoint changes are made gradually, preventing the compressor from cycling unnecessarily. It does this by internally filtering the setpoints to avoid reaching the differential-to-stop or the demand limit. Soft loading applies to the leaving chilled-water temperature and demand limit setpoints.

### Adaptive Controls

Adaptive Controls directly sense the control variables that govern the operation of the chiller: evaporator pressure and condenser pressure. When any one of these variables approaches a limit condition when damage may occur to the unit or shutdown on a safety, Adaptive Controls takes corrective action to avoid shutdown and keep the chiller operating. This happens through combined actions of compressor and/or fan staging. Whenever possible, the chiller is allowed to continue making chilled water. This keeps cooling capacity available until the problem can be solved. Overall, the safety controls help keep the building or process running and out of trouble.

### Rapid Restart

A Rapid Restart™ is performed after a momentary power loss occurs during operation. Similarly, if the chiller shuts down on a non-latching diagnostic and the diagnostic later clears itself, a Rapid Restart™ will be initiated.

### AdaptiSpeed Control

Compressor speed is used to control capacity of the chiller, optimizing mathematically with the condenser fan speed to provide the highest level of performance. The increased performance of the UC800 Controller allows the chiller to operate longer at higher efficiency, and with greater stability.

## Tracer AdaptiView TD7 Operator Interface

The standard Tracer AdaptiView™ TD7 display provided with the UC800 controller features a 7" LCD touch-screen, allowing access to all operational inputs and outputs. This is an advanced interface that allows the user to access any important information concerning setpoints, active temperatures, modes, electrical data, pressure, and diagnostics. It uses full text display available in 26 languages.

### Display Features Include:

- LCD touch-screen with LED backlighting, for scrolling access to input and output operating information
- Single-screen, folder/tab-style display of all available information on individual components (evaporator, condenser, compressor, etc.)
- Manual override indication
- Password entry/lockout system to enable or disable display
- Automatic and immediate stop capabilities for standard or immediate manual shutdown

- Fast, easy access to available chiller data in tabbed format, including:
  - Easy to view Operating Modes
  - Logical Sub-Component Reports:
    - Evaporator
    - Condenser
    - Compressor
    - Motor
  - 3 User Programmable Custom Reports
  - ASHRAE report
  - Logsheets Report
  - Alarms Report
  - 8 pre-defined Standard Graphs
  - 4 User Programmable Custom Graphs
  - Chiller Settings
  - Feature Settings
  - Chilled Water Reset
  - Manual Control Settings
  - Globalization Settings
  - Support of 26 languages
  - Brightness Setting
  - Cleaning Mode

## System Integration

### Stand-Alone Controls

Single chillers installed in applications without a building management system are simple to install and control: only a remote auto/stop for scheduling is required for unit operation. Signals from the chilled-water pump contactor auxiliary, or a flow switch, are wired to the chilled-water flow interlock. Signals from a time clock or some other remote device are wired to the external auto/stop input.

- Auto/Stop - A job-site provided contact closure turns the unit on and off.
- Emergency Stop - A job-site provided contact opening wired to this input turns the unit off and requires a manual reset of the unit microcomputer. This closure is typically triggered by a job-site provided system such as a fire alarm.

### Hardwire Points

Microcomputer controls allow simple interface with other control systems, such as time clocks, building automation systems, and ice storage systems via hardwire points. This means you have the flexibility to meet job requirements while not having to learn a complicated control system.

Remote devices are wired from the control panel to provide auxiliary control to a building automation system. Inputs and outputs can be communicated via a typical 4–20 mA electrical signal, an equivalent 2–10 Vdc signal, or by utilizing contact closures.

This setup has the same features as a stand-alone water chiller, with the possibility of having additional optional features:

- Ice making control
- External chilled water setpoint, external demand limit setpoint
- Chilled water temperature reset



- Programmable relays - available outputs are: alarm-latching, alarm-auto reset, general alarm-warning, chiller limit mode, compressor running, and Tracer control.

## BACnet Interface

Tracer® AdaptiView™ control can be configured for BACnet® communications at the factory or in the field. This enables the chiller controller to communicate on a BACnet® MS/TP network. Chiller setpoints, operating modes, alarms, and status can be monitored and controlled through BACnet®.

Tracer® AdaptiView™ controls conform to the BACnet® B-ASC profile as defined by ASHRAE 135-2004.

## LonTalk Communications Interface (LCI-C)

The optional LonTalk® Communications Interface for Chillers (LCI-C) is available factory or field installed. It is an integrated communication board that enables the chiller controller to communicate over a LonTalk® network. The LCI-C is capable of controlling and monitoring chiller setpoints, operating modes, alarms, and status. The Trane LCI-C provides additional points beyond the standard LONMARK® defined chiller profile to extend interoperability and support a broader range of system applications. These added points are referred to as open extensions. The LCI-C is certified to the LONMARK® Chiller Controller Functional Profile 8040 version 1.0, and follows LonTalk® FTT-10A free topology communications.

## Modbus Interface

Tracer® AdaptiView™ control can be configured for Modbus™ communications at the factory or in the field. This enables the chiller controller to communicate as a slave device on a Modbus™ network. Chiller setpoints, operating modes, alarms, and status can be monitored and controlled by a Modbus™ master device.

## Tracer SC

The Tracer® SC system controller acts as the central coordinator for all individual equipment devices on a Tracer® building automation system. The Tracer® SC scans all unit controllers to update information and coordinate building control, including building subsystems such as VAV and chiller water systems. With this system option, the full breadth of Trane's HVAC and controls experience are applied to offer solutions to many facility issues. The LAN allows building operators to manage these varied components as one system from any personal computer with web access. The benefits of this system are:

- Improved usability with automatic data collection, enhanced data logging, easier to create graphics, simpler navigation, pre-programmed scheduling, reporting, and alarm logs.
- Flexible technology allows for system sizes from 30 to 120 unit controllers with any combination of LonTalk® or BACnet® unit controllers.
- LEED certification through site commissioning report, energy data collection measurement, optimizing energy performance, and maintaining indoor air quality.

Energy savings programs include: fan pressure optimization, ventilation reset, and chiller plant control (adds and subtracts chillers to meet cooling loads).

## Building Automation and Chiller Plant Control

The UC800 controller can communicate with Trane Tracer® SC and Tracer® ES building automation systems, which include pre-engineered and flexible control for chiller plants. These building automation systems can control the operation of the complete installation: chillers, pumps, isolating valves, air handlers, and terminal units. Trane can undertake full responsibility for optimized automation and energy management for the entire chiller plant. The main functions are:

- **Chiller sequencing:** equalizes the number of running hours of the chillers. Different control strategies are available depending on the configuration of the installation.

- **Control of the auxiliaries:** includes input/output modules to control the operation of the various auxiliary equipment (water pumps, valves, etc.)
- **Time-of-day scheduling:** allows the end user to define the occupancy period, for example: time of the day, holiday periods and exception schedules.
- **Optimization of the installation start/stop time:** based on the programmed schedule of occupancy and the historical temperature records. Tracer SC calculates the optimal start/stop time of the installation to get the best compromise between energy savings and comfort of the occupants.
- **Soft loading:** the soft loading function minimizes the number of chillers that are operated to satisfy a large chilled-water-loop pull down, thus preventing an overshoot of the actual capacity required. Unnecessary starts are avoided and the peak current demand is lowered.
- **Communication capabilities:** local, through a PC workstation keyboard. Tracer® SC can be programmed to send messages to other local or remote workstations and or a pager in the following cases:
  - Analog parameter exceeding a programmed value
  - Maintenance warning
  - Component failure alarm
  - Critical alarm messages. In this latter case, the message is displayed until the operator acknowledges the receipt of the information. From the remote station it is also possible to access and modify the chiller plants control parameters.
- **Remote communication through a modem:** as an option, a modem can be connected to communicate the plant operation parameters through voice grade phone lines. A remote terminal is a PC workstation equipped with a modem and software to display the remote plant parameters.

## Integrated Comfort System (ICS)

The onboard chiller controller is designed to be able to communicate with a wide range of building automation systems. In order to take full advantage of chiller's capabilities, incorporate your chiller into a Tracer® SC building automation system.

But the benefits do not stop at the chiller plant. At Trane, we realize that all the energy used in your cooling system is important. That is why we worked closely with other equipment manufacturers to predict the energy required by the entire system. We used this information to create patented control logic for optimizing HVAC system efficiency.

The building owners challenge is to tie components and applications expertise into a single reliable system that provides maximum comfort, control, and efficiency. Trane® Integrated Comfort systems (ICS) are a concept that combines system components, controls, and engineering applications expertise into a single, logical, and efficient system. These advanced controls are fully commissioned and available on every piece of Trane equipment, from the largest chiller to the smallest VAV box. As a manufacturer, only Trane offers this universe of equipment, controls, and factory installation and verification.



# Electrical

## Electrical Data

Table 2. Electrical data, 60Hz, all ambients

Unit Size	Rated Voltage <sup>(a)</sup>	AFD Input Amps <sup>(b)</sup>		Fans			Control VA <sup>(c)</sup>		MCA <sup>(d)</sup>	MOP <sup>(e)</sup>
		Comp A	Comp B	Qty <sup>(f)</sup>	kW	FLA <sup>(g)</sup>	Without Harmonic Filtration <sup>(h)</sup>	With Harmonic Filtration <sup>(i)</sup>		
150	200	111	111	8	2.05	2.7	1394	n/a	632	800
	230	111	111	8	2.05	2.7	1394	n/a	550	700
	380	135	135	8	2.05	3.3	894	1394	334	450
	400	128	128	8	2.05	3.1	894	1394	317	400
	460	111	111	8	2.05	2.7	894	1394	275	350
	575	111	111	8	2.05	2.7	1394	n/a	220	300
165	200	117	117	10	2.05	2.7	1394	n/a	675	800
	230	117	117	10	2.05	2.7	1394	n/a	587	800
	380	141	141	10	2.05	3.3	894	1394	355	450
	400	134	134	10	2.05	3.1	894	1394	337	450
	460	117	117	10	2.05	2.7	894	1394	294	400
	575	117	117	10	2.05	2.7	1394	n/a	235	300
180	200	132	132	10	2.05	2.7	1394	n/a	753	1000
	230	132	132	10	2.05	2.7	1394	n/a	655	800
	380	159	159	10	2.05	3.3	894	1394	395	500
	400	151	151	10	2.05	3.1	894	1394	375	500
	460	132	132	10	2.05	2.7	894	1394	328	450
	575	132	132	10	2.05	2.7	1394	n/a	262	350
200	200	131	131	12	2.05	2.7	1394	n/a	760	1000
	230	131	131	12	2.05	2.7	1394	n/a	661	800
	380	159	159	12	2.05	3.3	894	1394	402	500
	400	151	151	12	2.05	3.1	894	1394	381	500
	460	131	131	12	2.05	2.7	894	1394	331	450
	575	131	131	12	2.05	2.7	1394	n/a	265	350
225	200	160	160	12	2.05	2.7	1434	n/a	910	1200
	230	160	160	12	2.05	2.7	1434	n/a	792	1000
	380	193	193	12	2.05	3.3	894	1434	478	600
	400	183	183	12	2.05	3.1	894	1434	453	600
	460	160	160	12	2.05	2.7	894	1434	396	500
	575	160	160	12	2.05	2.7	1434	n/a	317	400
250	200	168	168	12	2.05	2.7	1434	n/a	952	1200
	230	168	168	12	2.05	2.7	1434	n/a	828	1000
	380	204	204	12	2.05	3.3	894	1434	503	700
	400	194	194	12	2.05	3.1	894	1434	478	600
	460	168	168	12	2.05	2.7	894	1434	414	500
	575	168	168	12	2.05	2.7	1434	n/a	331	450

**Table 2. Electrical data, 60Hz, all ambients (continued)**

Unit Size	Rated Voltage <sup>(a)</sup>	AFD Input Amps <sup>(b)</sup>		Fans			Control VA <sup>(c)</sup>		MCA <sup>(d)</sup>	MOP <sup>(e)</sup>
		Comp A	Comp B	Qty <sup>(f)</sup>	kW	FLA <sup>(g)</sup>	Without Harmonic Filtration <sup>(h)</sup>	With Harmonic Filtration <sup>(i)</sup>		
275	200	202	202	14	2.05	2.7	1434	n/a	1140	1600
	230	202	202	14	2.05	2.7	1434	n/a	991	1200
	380	246	246	14	2.05	3.3	894	1434	604	800
	400	234	234	14	2.05	3.1	894	1434	574	800
	460	202	202	14	2.05	2.7	894	1434	496	600
	575	202	202	14	2.05	2.7	1434	n/a	396	500
300	200	200	200	16	2.05	2.7	1434	n/a	1142	1600
	230	200	200	16	2.05	2.7	1434	n/a	993	1200
	380	242	242	16	2.05	3.3	894	1434	602	800
	400	230	230	16	2.05	3.1	894	1434	571	800
	460	200	200	16	2.05	2.7	894	1434	497	600
	575	200	200	16	2.05	2.7	1434	n/a	398	500

- (a) Voltage Utilization Range: +/- 10% of Rated voltage (use range): 200/60/3 (180-220), 230/60/3 (208-254), 380/60/3 (342-418), 400/60/3 (360-440), 400/50/3 (360-440), 460/60/3 (414-506), 575/60/3 (516-633)
- (b) All 200, 230 and 575V units consist of a voltage autotransformer with a 460V unit downstream. As a result, AFD input amp draws for these voltages are the same as those of a corresponding 460V unit.
- (c) Control VA includes operational controls only. It does not include evaporator heaters. A separate 115/60/1, 15 amp customer provided power connection is required to power the evaporator heaters (150T-165T; 800 watts, 180T-300T; 1200 watts).
- (d) MCA - Minimum Circuit Ampacity - 125 percent of largest compressor VFD input plus 100 percent of all other loads for 380V, 400V, and 460V incoming voltage. All other voltages need to have the 460V calculation reflected to the appropriate voltage.
- (e) Max fuse or MOP = 225 percent of largest compressor VFD input plus 100 percent of second compressor VFD input, plus sum of condenser fan FLA.
- (f) Number of fans is evenly distributed between the two chiller circuits.
- (g) FLA values listed are the maximum possible. Some unit configurations may have lower FLA values.
- (h) Model number digit 29 = X.
- (i) Model number digit 29 = 1.



## Electrical

**Table 3. Electrical data, 50Hz, all ambients**

Unit Size	Rated Voltage <sup>(a)</sup>	AFD Input Amps		Fans			Control VA <sup>(b)</sup>		MCA <sup>(c)</sup>	MOP <sup>(d)</sup>
		Comp A	Comp B	Qty <sup>(e)</sup>	kW	FLA <sup>(f)</sup>	Without Harmonic Filtration <sup>(g)</sup>	With Harmonic Filtration <sup>(h)</sup>		
150	380	135	135	8	2.05	3.3	894	1394	334	450
	400	128	128	8	2.05	3.1	894	1394	317	400
165	380	141	141	10	2.05	3.3	894	1394	355	450
	400	134	134	10	2.05	3.1	894	1394	337	450
180	380	159	159	10	2.05	3.3	894	1394	395	500
	400	151	151	10	2.05	3.1	894	1394	375	500
200	380	159	159	12	2.05	3.3	894	1394	402	500
	400	151	151	12	2.05	3.1	894	1394	381	500
225	380	193	193	12	2.05	3.3	934	1434	478	600
	400	183	183	12	2.05	3.1	934	1434	453	600
250	380	204	204	12	2.05	3.3	934	1434	503	700
	400	194	194	12	2.05	3.1	934	1434	478	600
275	380	246	246	14	2.05	3.3	934	1434	604	800
	400	234	234	14	2.05	3.1	934	1434	574	800
300	380	242	242	16	2.05	3.3	934	1434	602	800
	400	230	230	16	2.05	3.1	934	1434	571	800

<sup>(a)</sup> Voltage Utilization Range: +/- 10% of Rated voltage (use range): 400/50/3 (360-440)

<sup>(b)</sup> Control VA includes operational controls only. It does not include evaporator heaters. A separate 115/60/1, 15 amp customer provided power connection is required to power the evaporator heaters (150T-165T; 800 watts, 180T-300T; 1200 watts).

<sup>(c)</sup> MCA - Minimum Circuit Ampacity - 125 percent of largest compressor VFD input plus 100 percent of all other loads for 380V, 400V, and 460V incoming voltage. All other voltages need to have the 460V calculation reflected to the appropriate voltage.

<sup>(d)</sup> Max fuse or MOP = 225 percent of largest compressor VFD input plus 100 percent of second compressor VFD input, plus sum of condenser fan FLA.

<sup>(e)</sup> Number of fans is evenly distributed between the two chiller circuits.

<sup>(f)</sup> FLA values listed are the maximum possible. Some unit configurations may have lower FLA values.

<sup>(g)</sup> Model number digit 29 = X.

<sup>(h)</sup> Model number digit 29 = 1.



# Customer Wiring

Table 4. Customer wire selection, 60Hz

Unit Size	Rated Voltage	Terminal Block	Circuit Breaker	Circuit Breaker (High Fault)
150	200	(2) 4AWG-500MCM	(3) 3/0-500MCM	(3) 3/0-500MCM
	230	(2) 4AWG-500MCM	(3) 3/0-500MCM	(3) 3/0-500MCM
	380	(2) 4AWG-500MCM	(2) 4/0-500MCM	(2) 4/0-500MCM
	400	(2) 4AWG-500MCM	(2) 4/0-500MCM	(2) 4/0-500MCM
	460	(2) 4AWG-500MCM	(2) 4/0-500MCM	(2) 4/0-500MCM
	575	(2) 4AWG-500MCM	(3) 3/0-500MCM	(3) 3/0-500MCM
165	200	(2) 4AWG-500MCM	(3) 3/0-500MCM	(3) 3/0-500MCM
	230	(2) 4AWG-500MCM	(3) 3/0-500MCM	(3) 3/0-500MCM
	380	(2) 4AWG-500MCM	(2) 4/0-500MCM	(2) 4/0-500MCM
	400	(2) 4AWG-500MCM	(2) 4/0-500MCM	(2) 4/0-500MCM
	460	(2) 4AWG-500MCM	(2) 4/0-500MCM	(2) 4/0-500MCM
	575	(2) 4AWG-500MCM	(3) 3/0-500MCM	(3) 3/0-500MCM
180	200	(2) 4AWG-500MCM	n/a	(4) 3/0-500MCM
	230	(2) 4AWG-500MCM	(3) 3/0-500MCM	(3) 3/0-500MCM
	380	(2) 4AWG-500MCM	(2) 4/0-500MCM	(2) 4/0-500MCM
	400	(2) 4AWG-500MCM	(2) 4/0-500MCM	(2) 4/0-500MCM
	460	(2) 4AWG-500MCM	(2) 4/0-500MCM	(2) 4/0-500MCM
	575	(2) 4AWG-500MCM	(3) 3/0-500MCM	(3) 3/0-500MCM
200	200	(2) 4AWG-500MCM	n/a	(4) 3/0-500MCM
	230	(2) 4AWG-500MCM	(3) 3/0-500MCM	(3) 3/0-500MCM
	380	(2) 4AWG-500MCM	(2) 4/0-500MCM	(2) 4/0-500MCM
	400	(2) 4AWG-500MCM	(2) 4/0-500MCM	(2) 4/0-500MCM
	460	(2) 4AWG-500MCM	(2) 4/0-500MCM	(2) 4/0-500MCM
	575	(2) 4AWG-500MCM	(3) 3/0-500MCM	(3) 3/0-500MCM
225	200	(2) 4AWG-500MCM	n/a	(4) 3/0-500MCM
	230	(2) 4AWG-500MCM	n/a	(4) 3/0-500MCM
	380	(2) 4AWG-500MCM	(2) 4/0-500MCM	(2) 4/0-500MCM
	400	(2) 4AWG-500MCM	(2) 4/0-500MCM	(2) 4/0-500MCM
	460	(2) 4AWG-500MCM	(2) 4/0-500MCM	(2) 4/0-500MCM
	575	(2) 4AWG-500MCM	(3) 3/0-500MCM	(3) 3/0-500MCM
250	200	(2) 4AWG-500MCM	n/a	(4) 3/0-500MCM
	230	(2) 4AWG-500MCM	n/a	(4) 3/0-500MCM
	380	(2) 4AWG-500MCM	(3) 3/0-500MCM	(3) 3/0-500MCM
	400	(2) 4AWG-500MCM	(2) 4/0-500MCM	(2) 4/0-500MCM
	460	(2) 4AWG-500MCM	(2) 4/0-500MCM	(2) 4/0-500MCM
	575	(2) 4AWG-500MCM	(3) 3/0-500MCM	(3) 3/0-500MCM
275	200	(2) 4AWG-500MCM	n/a	(4) 3/0-500MCM
	230	(2) 4AWG-500MCM	n/a	(4) 3/0-500MCM
	380	(2) 4AWG-500MCM	(3) 3/0-500MCM	(3) 3/0-500MCM
	400	(2) 4AWG-500MCM	(3) 3/0-500MCM	(3) 3/0-500MCM
	460	(2) 4AWG-500MCM	(3) 3/0-500MCM	(3) 3/0-500MCM
	575	(2) 4AWG-500MCM	(3) 3/0-500MCM	(3) 3/0-500MCM



**Electrical**

**Table 4. Customer wire selection, 60Hz (continued)**

Unit Size	Rated Voltage	Terminal Block	Circuit Breaker	Circuit Breaker (High Fault)
300	200	(2) 4AWG-500MCM	n/a	(4) 3/0-500MCM
	230	(2) 4AWG-500MCM	n/a	(4) 3/0-500MCM
	380	(2) 4AWG-500MCM	(3) 3/0-500MCM	(3) 3/0-500MCM
	400	(2) 4AWG-500MCM	(3) 3/0-500MCM	(3) 3/0-500MCM
	460	(2) 4AWG-500MCM	(2) 4/0-500MCM	(2) 4/0-500MCM
	575	(2) 4AWG-500MCM	(3) 3/0-500MCM	(3) 3/0-500MCM

**Note:** Field wire insulation temperature rating must be minimum 90°C unless otherwise specified.

**Table 5. Customer wire selection, 50Hz**

Unit Size	Rated Voltage	Terminal Block	Circuit Breaker	Circuit Breaker (High Fault)
150	380	(2) 4AWG-500MCM	(2) 4/0-500MCM	(2) 4/0-500MCM
	400	(2) 4AWG-500MCM	(2) 4/0-500MCM	(2) 4/0-500MCM
165	380	(2) 4AWG-500MCM	(2) 4/0-500MCM	(2) 4/0-500MCM
	400	(2) 4AWG-500MCM	(2) 4/0-500MCM	(2) 4/0-500MCM
180	380	(2) 4AWG-500MCM	(2) 4/0-500MCM	(2) 4/0-500MCM
	400	(2) 4AWG-500MCM	(2) 4/0-500MCM	(2) 4/0-500MCM
200	380	(2) 4AWG-500MCM	(2) 4/0-500MCM	(2) 4/0-500MCM
	400	(2) 4AWG-500MCM	(2) 4/0-500MCM	(2) 4/0-500MCM
225	380	(2) 4AWG-500MCM	(2) 4/0-500MCM	(2) 4/0-500MCM
	400	(2) 4AWG-500MCM	(2) 4/0-500MCM	(2) 4/0-500MCM
250	380	(2) 4AWG-500MCM	(3) 3/0-500MCM	(3) 3/0-500MCM
	400	(2) 4AWG-500MCM	(2) 4/0-500MCM	(2) 4/0-500MCM
275	380	(2) 4AWG-500MCM	(3) 3/0-500MCM	(3) 3/0-500MCM
	400	(2) 4AWG-500MCM	(3) 3/0-500MCM	(3) 3/0-500MCM
300	380	(2) 4AWG-500MCM	(3) 3/0-500MCM	(3) 3/0-500MCM
	400	(2) 4AWG-500MCM	(3) 3/0-500MCM	(3) 3/0-500MCM

**Note:** Field wire insulation temperature rating must be minimum 90°C unless otherwise specified.

Page left intentionally blank

# Electrical Connections

Figure 5. Field wiring

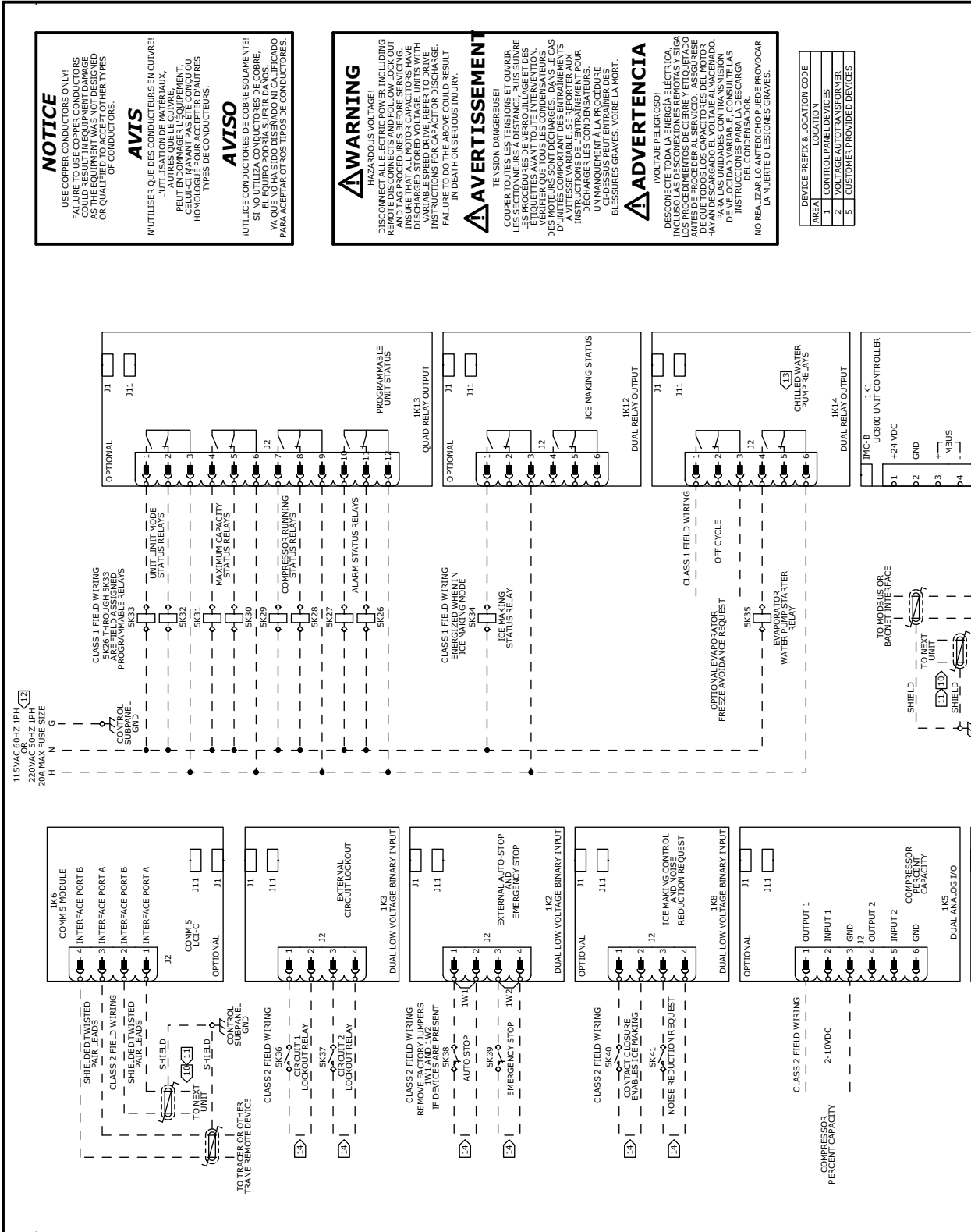

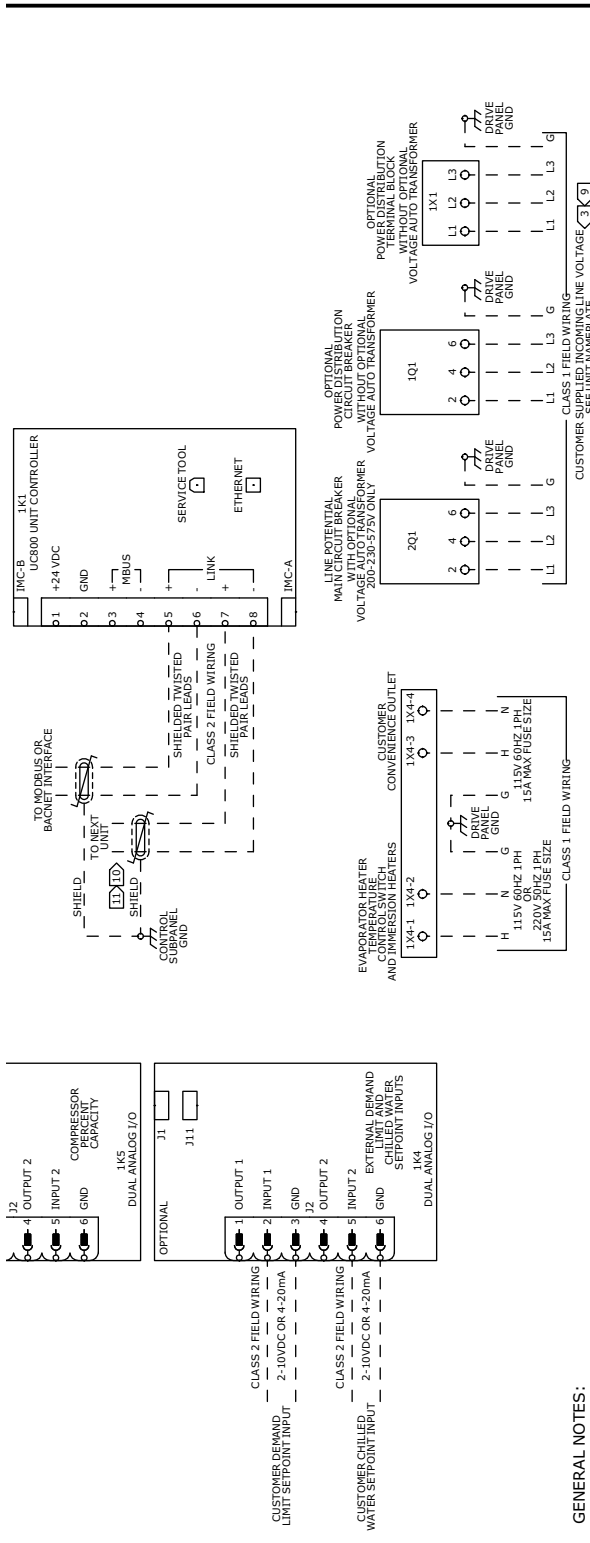

- GENERAL NOTES:**
1. WIRE REPRESENTED BY DASHED LINES INDICATE RECOMMENDED FIELD WIRING BY OTHERS.
  2. ALL STANDARD AND OPTIONAL COMPONENTS SHOWN.
  3. DO NOT RUN LOW VOLTAGE CONTROL WIRING (30V OR LESS) IN CONDUIT WITH 110V OR HIGHER WIRING. DO NOT RUN LOW VOLTAGE CONTROL WIRING WITH A MAXIMUM RUN LENGTH FOR A GIVEN SIZE: 14 AWG OF 5000 FT, 16 AWG OF 2000 FT OR 18 AWG OF 1000 FT.
  4. ALL MOTORS ARE PROTECTED FROM PRIMARY SINGLE PHASE FAILURES.
  5. CONTROL WIRING SHOULD BE PROTECTED FROM MECHANICAL DAMAGE. CHILLED WATER PUMP MUST BE CONTROLLED BY THE CHILLER OUTPUT FAILURE TO COMPLY WITH THIS REQUIREMENT MAY RESULT IN DAMAGE TO THE UNIT.
  6. CAUTION - DO NOT ENERGIZE THE UNIT UNTIL CHECK OUT AND STARTUP PROCEDURES HAVE BEEN COMPLETED.

**WIRING REQUIREMENTS:**

7. ALL FIELD WIRING MUST BE IN ACCORDANCE WITH THE NATIONAL ELECTRIC CODE (NEC), STATE AND LOCAL CODES. DO NOT RUN LOW VOLTAGE CONTROL WIRING (30V OR LESS) IN CONDUIT WITH 110V OR HIGHER WIRING. DO NOT RUN LOW VOLTAGE CONTROL WIRING WITH A MAXIMUM RUN LENGTH FOR A GIVEN SIZE: 14 AWG OF 5000 FT, 16 AWG OF 2000 FT OR 18 AWG OF 1000 FT.
8. ALL UNIT POWER WIRING MUST BE 600V COPPER CONDUCTORS ONLY AND HAVE A MINIMUM TEMPERATURE INSULATION RATING OF 90°C. REFER TO UNIT MANUFACTURER FOR MINIMUM CIRCUIT AMPACITY AND MAXIMUM WIRING METHODS. REFER TO WIRE RANGE TABLE FOR WIRE SIZES.
9. SHIELDED TWISTED PAIR LEADS ARE REQUIRED FOR CONNECTIONS TO THE COMMUNICATIONS INTERFACE MODULES (IK1 OR OPTIONAL IK6). THE SHIELD SHOULD BE GROUNDED AT THE UNIT CONTROL PANEL END.
10. 22 AWG SHIELDED COMMUNICATION WIRE EQUIVALENT TO HELIX LP22P0014216 IS RECOMMENDED FOR WIRING TO NEXT UNIT. THE SUM TOTAL OF ALL INTERCONNECTED CABLE SEGMENTS ARE NOT TO EXCEED 4800 FT. CONNECTION TO NEXT UNIT SHALL BE MADE TO THE COMMUNICATIONS SYSTEM (BAS) COMMUNICATION INSTALLATION LITERATURE FOR END OF LINE TERMINATION RESISTOR REQUIREMENTS.
11. ALL CUSTOMER SUPPLIED CONTROL CIRCUIT WIRING MUST BE COPPER CONDUCTORS ONLY AND HAVE A MINIMUM INSULATION RATING OF 90V. EXCEPT AS NOTED, ALL CUSTOMER WIRING CONNECTIONS ARE MADE TO CIRCUIT BOARD MOUNTED TERMINALS WITH A WIRE RANGE OF 14 TO 18 AWG OR TO DIN RAIL MOUNTED SPRING FORCE TERMINALS.

**CONTACT RATINGS AND REQUIREMENTS:**

12. UNIT PROVIDED DRY CONTACTS FOR THE CONDENSER / CHILLED WATER PUMP CONTROL. RELAY CONTACT RATINGS AT 120VAC: 7.2A RESISTIVE, 2.88A PILOT DUTY, OR 1/3 HP, 7.2 FLA. CONTACTS ARE RATED FOR 40WAC, 5A GENERAL PURPOSE DUTY.
13. CUSTOMER SUPPLIED CONTACTS FOR ALL LOW VOLTAGE CONNECTIONS MUST BE COMPATIBLE WITH DRY CIRCUIT 24VDC FOR A 12mA RESISTIVE LOAD. SILVER OR GOLD PLATED CONTACTS ARE RECOMMENDED.

**TRANE®**  
DIAGRAM  
UNIT FIELD WIRING

ACRA GP4 - 2 COMPRESSORS

DRAWING NUMBER  
**23115014**

REV  
1 OF 1  
**B**

DRAWN BY: K.M. KULLIG  
DATE: 24 AUG 2018  
MASTER FILE:  
REVISION DATE: 03 JAN 2019  
REPLACES:  
SIMILAR TO: 23111961  
USED BY:

THIS DRAWING IS AN ARBITRARY AND SHALL NOT BE COPIED OR OUTSIDE PARTS WITHOUT THE WRITTEN CONSENT OF TRANE  
CAD: CREO SCHEMATICS



# Dimensions and Weights

## Weights

Table 6. Unit weights

Unit Size (tons)	Standard Length				Extended Length			
	Shipping		Operating		Shipping		Operating	
	lb	kg	lb	kg	lb	kg	lb	kg
InvisiSound™ Standard or Superior								
150	11333	5141	11479	5207	13492	6120	13638	6186
165	12377	5614	12533	5685	14532	6592	14688	6662
180	12698	5760	12881	5843	14853	6737	15036	6820
200	13808	6263	14008	6354	15991	7254	16191	7344
225	15244	6915	15466	7015	17427	7905	17649	8006
250	15622	7086	15862	7195	17805	8076	18045	8185
275	16820	7630	17095	7754	18975	8607	19250	8732
300	17965	8149	18265	8285	20121	9127	20421	9263
InvisiSound™ Ultimate								
150	12133	5504	12279	5570	14292	6483	14438	6549
165	13177	5977	13333	6048	15332	6955	15488	7025
180	13498	6123	13681	6206	15653	7100	15836	7183
200	14608	6626	14808	6717	16791	7616	16991	7707
225	16044	7278	16266	7378	18227	8268	18449	8368
250	16422	7449	16662	7558	18605	8439	18845	8548
275	17620	7992	17895	8117	19775	8970	20050	9095
300	18765	8512	19040	8636	20921	9490	21196	9614

**Notes:**

1. Weights include factory charge of refrigerant and oil, as well as architectural louvered panels. See Unit Length section of General Data chapter to determine unit length.
2. Model number digit 12 = 1 or 2
3. Model number digit 12 = 3

## Service Clearance

**Figure 6. Unit service clearance requirements**

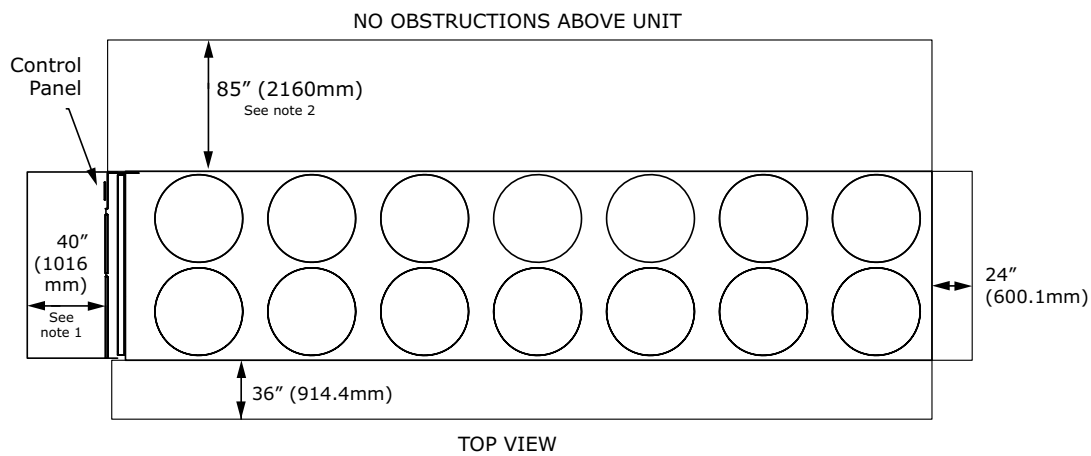

**Notes:**

1. A full 40" clearance is required in front of the control panel. Must be measured from front of panel, not end of unit base.
2. Clearance of 85" on the side of the unit is required for coil replacement. Preferred side for coil replacement is shown (left side of the unit, as facing control panel), however either side is acceptable.

# Unit Dimensions

Figure 7. Unit dimensions, standard length

## 3 PASS OPTION

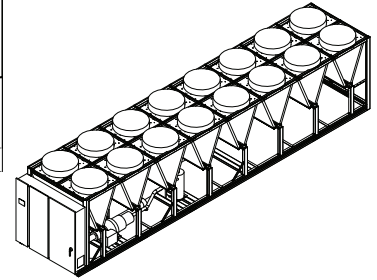
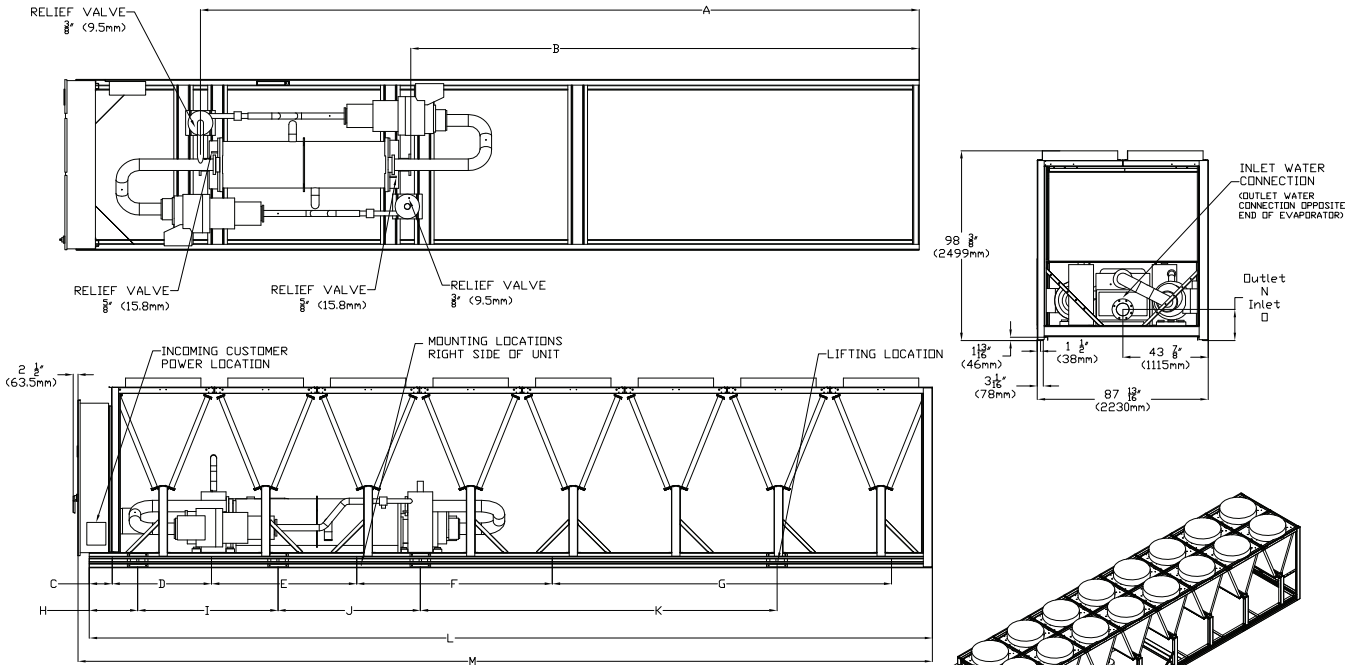

## 2 PASS OPTION

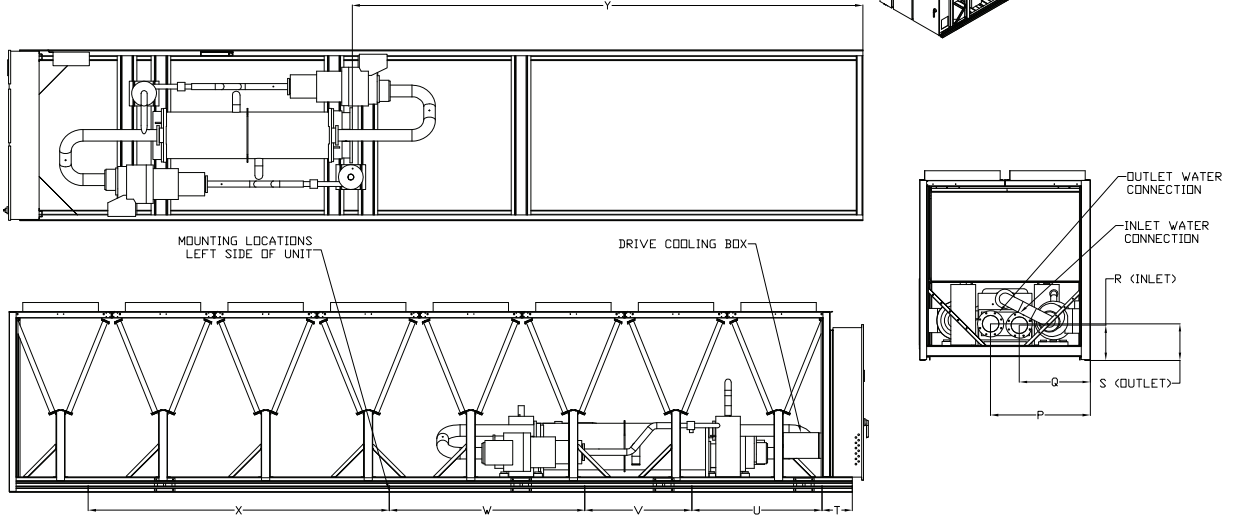
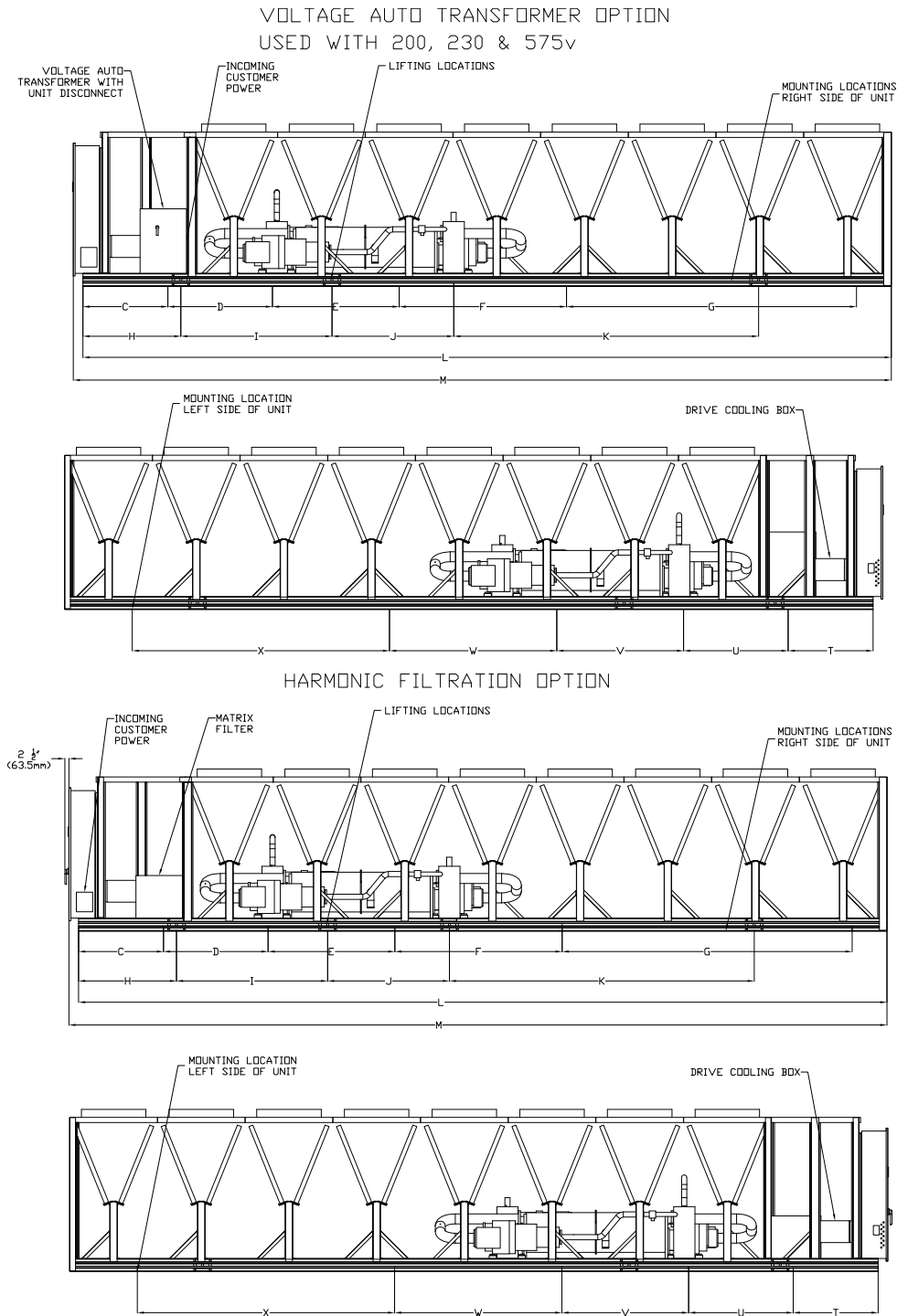



Table 7. Unit dimensions, standard length

Dim	Unit Size													
	150		165		180		200		225, 250		275		300	
	in	mm	in	mm	in	mm	in	mm	in	mm	in	mm	in	mm
A	158.6	4027.0	211.4	5368.8	212.5	5397.4	265.3	6739.5	265.3	6739.5	318.1	8080.5	370.9	9422.5
B	52.4	1330.0	105.2	2671.9	103.5	2629.4	156.4	3971.5	156.4	3971.5	209.0	5308.5	261.8	6650.5
C	11.8	300.0	11.8	300.0	11.8	300.0	11.8	300.0	11.8	300.0	11.8	300.0	11.8	300.0
D	51.2	1300.0	51.2	1300.0	51.2	1300.0	51.2	1300.0	51.2	1300.0	51.2	1300.0	51.2	1300.0
E	78.8	2000.0	74.8	1900.0	74.8	1900.0	74.8	1900.0	74.8	1900.0	61.4	1560.0	74.8	1900.0
F	63.0	1600.0	118.1	3000.0	118.1	3000.0	100.8	2560.0	100.8	2560.0	72.4	1840.0	100.8	2560.0
G							76.4	1940.0	76.4	1940.0	137.8	3500.0	174.8	4440.0
H	25.0	635.0	25.0	635.0	25.0	635.0	25.0	635.0	25.0	635.0	25.0	635.0	25.0	635.0
I	128.1	3255.0	145.6	3699.0	145.6	3699.0	65.9	1674.0	65.9	1674.0	65.9	1674.0	65.9	1674.0
J							120.5	3061.0	120.5	3061.0	158.5	4026.0	79.7	2024.0
K													184.5	4686.0
L	223.0	5663.5	275.8	7005.5	275.8	7005.5	328.6	8347.5	328.6	8347.5	381.5	9689.5	434.3	11031.5
M	228.9	5813.0	281.7	7155.0	281.7	7155.0	334.5	8497.0	334.5	8497.0	387.4	9839.0	440.2	11181.0
N	20.4	519.5	20.4	519.5	19.6	497.5	19.6	497.5	19.6	497.5	21.8	553.6	20.6	522.5
O	17.7	449.5	17.7	449.5	15.4	390.5	15.4	390.5	15.4	390.5	17.6	446.6	16.1	407.7
P	49.3	1252.5	49.3	1252.5	49.9	1268.0	49.9	1268.0	49.9	1268.0	51.3	1303.3	51.3	1303.3
Q	38.5	977.5	38.5	977.5	37.9	962.0	37.9	962.0	37.9	962.0	36.5	927.3	36.5	927.3
R	19.3	489.5	19.3	489.5	17.6	447.5	17.6	447.5	17.6	447.5	19.8	503.6	18.2	462.5
S	19.7	499.5	19.7	499.5	18.2	462.5	18.2	462.5	18.2	462.5	20.4	518.6	18.9	480.5
T	15.8	400.0	15.8	400.0	15.8	400.0	15.8	400.0	15.8	400.0	15.8	400.0	15.8	400.0
U	66.9	1700.0	66.9	1700.0	66.9	1700.0	66.9	1700.0	66.9	1700.0	66.9	1700.0	66.9	1700.0
V	59.1	1500.0	55.1	1400.0	55.1	1400.0	55.1	1400.0	55.1	1400.0	41.8	1060.0	55.1	1400.0
W	63.0	1600.0	118.1	3000.0	118.1	3000.0	100.8	2560.0	100.8	2560.0	72.4	1840.0	100.8	2560.0
X							76.4	1940.0	76.4	1940.0	137.8	3500.0	155.1	3940.0
Y	53.6	1362.5	106.5	2704.4	105.5	2679.4	158.3	4021.5	158.3	4021.5	210.3	5340.0	263.1	6682.0

**Figure 8. Unit dimensions, extended length**



**Table 8. Unit dimensions, extended length**

Dim	Unit Size													
	150		165		180		200		225, 250		275		300	
	in	mm	in	mm	in	mm	in	mm	in	mm	in	mm	in	mm
A	158.6	4027.0	211.4	5368.8	212.5	5397.4	265.3	6739.5	265.3	6739.5	318.1	8080.5	370.9	9422.5
B	52.4	1330.0	105.2	2671.9	103.5	2629.4	156.4	3971.5	156.4	3971.5	209.0	5308.5	261.8	6650.5
C	27.6	700.0	27.6	700.0	27.6	700.0	51.2	1300.0	51.2	1300.0	51.2	1300.0	51.2	1300.0
D	86.6	2200.0	86.6	2200.0	86.6	2200.0	63.0	1600.0	63.0	1600.0	63.0	1600.0	63.0	1600.0
E	80.4	2042.0	76.4	1942.0	76.4	1942.0	76.4	1942.0	76.4	1942.0	63.1	1602.0	76.4	1942.0
F	63.0	1600.0	118.1	3000.0	118.1	3000.0	59.1	1500.0	59.1	1500.0	72.4	1840.0	100.8	2560.0
G							118.1	3000.0	118.1	3000.0	137.8	3500.0	174.8	4440.0
H	55.1	1400.0	55.1	1400.0	55.1	1400.0	58.3	1482.0	58.3	1482.0	58.3	1482.0	58.3	1482.0
I	150.9	3832.0	168.4	4276.0	168.4	4276.0	85.4	2169.0	85.4	2169.0	85.4	2169.0	85.4	2169.0
J							120.5	3061.0	120.5	3061.0	158.5	4026.0	79.7	2024.0
K													184.5	4686.0
L	275.8	7005.5	328.6	8347.5	328.6	8347.5	381.5	9689.5	381.5	9689.5	434.3	11031.5	487.1	12373.5
M	281.7	7155.0	334.5	8497.0	334.5	8497.0	387.4	9839.0	387.4	9839.0	440.2	11181.0	493.0	12523.0
N	20.4	519.5	20.4	519.5	19.6	497.5	19.6	497.5	19.6	497.5	21.8	553.6	20.6	522.5
O	17.7	449.5	17.7	449.5	15.4	390.5	15.4	390.5	15.4	390.5	17.6	446.6	16.1	407.7
P	49.3	1252.5	49.3	1252.5	49.9	1268.0	49.9	1268.0	49.9	1268.0	51.3	1303.3	51.3	1303.3
Q	38.5	977.5	38.5	977.5	37.9	962.0	37.9	962.0	37.9	962.0	36.5	927.3	36.5	927.3
R	19.3	489.5	19.3	489.5	17.6	447.5	17.6	447.5	17.6	447.5	19.8	503.6	18.2	462.5
S	19.7	499.5	19.7	499.5	18.2	462.5	18.2	462.5	18.2	462.5	20.4	518.6	18.9	480.5
T	27.6	700.0	27.6	700.0	27.6	700.0	51.2	1300.0	51.2	1300.0	51.2	1300.0	51.2	1300.0
U	86.6	2200.0	86.6	2200.0	86.6	2200.0	63.0	1600.0	63.0	1600.0	63.0	1600.0	63.0	1600.0
V	80.4	2042.0	76.4	1942.0	76.4	1942.0	76.4	1942.0	76.4	1942.0	63.1	1602.0	76.4	1942.0
W	63.0	1600.0	118.1	3000.0	118.1	3000.0	59.1	1500.0	59.1	1500.0	72.4	1840.0	63.0	1600.0
X							118.1	3000.0	118.1	3000.0	137.8	3500.0	155.1	3940.0
Y	53.6	1362.5	106.5	2704.4	105.5	2679.4	158.3	4021.5	158.3	4021.5	210.3	5340.0	263.1	6682.0



# Mechanical Specifications

## General

Units are leak tested, pressure tested, then evacuated and charged. All chillers are factory tested prior to shipment. Packaged units ship with a full operating charge of oil and refrigerant as standard. Units can also be shipped with a nitrogen charge if required. Unit panels, structural elements and control boxes are constructed of galvanized steel and mounted on a bolted galvanized steel base. Unit panels, control boxes and the structural base are finished with a baked on powder paint.

## Certified AHRI Performance

Trane air-cooled chillers are rated within the scope of the Air-Conditioning, Heating & Refrigeration Institute (AHRI) Certification Program and display the AHRI Certified® mark as a visual confirmation of conformance to the certification sections of AHRI Standard 550/590 (I-P) and ANSI/AHRI Standard 551/591 (SI). The applications in this catalog specifically excluded from the AHRI certification program are:

- Custom Units
- Units produced outside of the USA for installations outside the USA
- Evaporatively-cooled chillers
- Units with evaporators that use fluid other than fresh water except units containing freeze protection fluids in the evaporator with a leaving chilled fluid temperature above 32°F [0°C] are certified when rated per the Standard with water.

## Refrigeration Circuits

All chiller sizes are designed with two refrigerant circuits.

Each refrigeration circuit includes one rotary screw compressor, a compressor suction and discharge service valve, liquid line shutoff valve, removable core filter, liquid line sight glass with moisture indicator, charging port and an electronic expansion valve. Fully modulating variable volume ratio compressors and electronic expansion valves provide variable capacity modulation over the entire operating range.

## Evaporator

The evaporator is a tube-in-shell heat exchanger design constructed from carbon steel shells and tubesheets with internally and externally finned seamless copper tubes mechanically expanded into the tube sheets. The evaporator is designed, tested and stamped in accordance with the ASME Boiler and Pressure Vessel Code for a refrigerant side working pressure of 200 psig. The evaporator is designed for a water side working pressure of 150 psig. Standard water connections are grooved for Victaulic style pipe couplings, with groove to flange style adapters available. Waterboxes are available in 2 and 3 pass configurations and include a vent, a drain and fittings for temperature control sensors. Evaporators are insulated with 3/4 inch closed cell insulation. Evaporator water heaters with thermostat are provided to help protect the evaporator from freezing at ambient temperatures down to -20°F (-29°C). A factory installed flow switch is installed on the supply water box in the evaporator inlet connection.

## Condenser and Fans

Air-cooled condenser coils have aluminum fins mechanically bonded to internally finned seamless aluminum tubing. The tubing is a long life alloy designed to deliver corrosion performance that meets or exceeds microchannel coils. The condenser coil has an integral subcooling circuit. Condensers are factory proof tested at 525 psig and leak tested with helium in a mass spectrometer chamber at 150 psig. All tube connections are mechanical except the brazed copper to aluminum inlet and outlet connections. The copper to aluminum connections are protected against galvanic corrosion. Corrosion resistant coil coating is available if the installation site is near the ocean or in an otherwise corrosive environment. See Options chapter.

Condenser fans are direct-drive vertical discharge. The condenser fan motors are permanent magnet motors with integrated drive to provide variable speed fan control for all fans and are designed with permanently lubricated ball bearings, internal temperature and current overload protection, and customer fault feedback as a standard product offering. The fan impeller is a nine bladed-shrouded fan made from heavy-duty molded plastic.

## Compressor and Lube Oil System

The rotary screw compressor is variable volume ratio semi-hermetic, direct drive with capacity control via a variable speed drive, rolling element bearings, differential refrigerant pressure oil flow and oil heater. The motor is a suction gas cooled, hermetically sealed, permanent magnet motor. An oil separator is provided separate from the compressor. Oil filtration is provided internal to the compressor.

## Drive Cooling System

Each refrigeration circuit has a compressor drive cooling circuit. Each drive cooling circuit includes a wet rotor circulation pump that circulates a secondary heat transfer fluid in a closed system between the adaptive frequency drive components in the control panel and a brazed plate heat exchanger. The pump is fed from a thermal expansion tank with a vented-pressure cap which is also used as the circuit pressure relief. Pressure relief for the drive cooling loop is set at 16 psig. The circuit also includes a particulate strainer and a drain valve for servicing.

## Unit Controls

All unit controls are housed in an outdoor rated weather tight enclosure with removable plates to allow for customer connection of power wiring and remote interlocks. All controls, including sensors, are factory mounted and tested prior to shipment.

Microcomputer controls provide all control functions including startup and shut down, leaving chilled water temperature control, evaporator flow proving, compressor staging and speed control, electronic expansion valve modulation, condenser fan sequencing and speed control, anti-recycle logic, automatic lead/lag compressor starting, and load limiting.

### Tracer UC800

The Tracer® UC800 unit control module, utilizing Adaptive Control™ microprocessor, automatically takes action to avoid unit shut-down due to abnormal operating conditions associated with low refrigerant pressure, high condensing pressure, AFD/Compressor current overload, low oil return or low AFD cooling, low discharge superheat, and high compressor discharge temperature. Should the abnormal operating condition continue until a protective limit is violated, the unit will be shut down.

Unit protective functions of the UC800 include: loss of chilled water flow, evaporator freezing, loss of refrigerant, low refrigerant pressure, high refrigerant pressure, high compressor motor temperature, and loss of oil to the compressor.

### Tracer AdaptiView TD7 Display

A full color Tracer AdaptiView™ TD7 touch screen display indicates all important unit and circuit parameters, in logical groupings on various screens. The parameters including chilled water set point, leaving chilled water temperature, demand limit set point, evaporator and condenser refrigerant temperatures and pressures, compressor and fan speeds, and all pertinent electrical information. The display also provides "on screen" trending graphs of predefined parameters as well as customizable trend graphs based on user defined parameters from a list of all available parameters. The display also provides indication of the chiller and circuits' top level operating modes with detailed sub-mode reports available with a single key press, as well as diagnostics announcement and date and time stamped diagnostic history. The color display is fully outdoor rated, and, can be viewed in full daylight without opening any control panel doors.

Standard power connections include main three phase power to the compressors, condenser fans and control power transformer and optional connections are available for the 115 volt/60 Hz single phase power for the thermostatically controlled evaporator heaters for freeze protection.



## Mechanical Specifications

---

- Outdoor capable:
  - Removable Cover
  - UV Resistant Touchscreen
  - -40°C to 70°C Operating Temperature
  - IP56 rated (Power Jets of Water from all directions)
- RoHS Compliant
- UL 916 Listed
- CE Certification
- Emissions: EN55011 (Class B)
- Immunity: EN61000 (Industrial)
- Display:
  - 7 inch diagonal
  - 800x480 pixels
  - TFT LCD @ 600 nits brightness
  - 16 bit color graphic display
- Display Features:
  - Alarms
  - Reports
  - Chiller Settings
  - Display Settings
- Graphing
- Global Application with Support for 26 Languages

## Adaptive Frequency Drive

The compressors on the ACR chillers are driven by Adaptive Frequency Drives (AFD). The drives are hybrid cooled by both water/glycol through the chillplate to cool the power electronics and also forced air for other components in the drive. The drives include custom programming for Trane application to provide chiller specific protections and stable compressor operation across the operating map. Protections include compressor overload, low or high line voltage, output phase loss, input phase loss, drive overheating, and more. The drives communicate over a serial connection (Modbus) to the Tracer® UC800 unit control module for run-time control, real-time data feedback, and diagnostics.

## Chilled Water Reset

Control logic and factory installed sensors are provided to reset leaving chilled water temperature. The set point can be reset based on ambient temperature or return evaporator water temperature.

## Factory Mounted Flow Proving and Flow Control

The factory installed evaporator water flow switch is provided with the control logic and relays to turn the chilled water flow on and off as the chiller requires for operation and protection. This function is a requirement on the chiller.



# Options

## Application Options

### Ice Making

The ice making option provides special control logic to handle low temperature brine applications (less than 40°F [4.4°C] leaving evaporator temperature) for thermal storage applications.

### Low Temperature Fluid

Low temperature option provides special control logic to handle low temperature brine applications including part load conditions below 40°F (4.4°C) leaving evaporator temperature.

### Low Ambient Option

The low ambient options adds hardware and unit controls to allow start and operation down to ambient temperatures of 0°F (-17.7°C).

### Extreme Low Ambient Option

The low ambient options adds hardware and unit controls to allow operation down to ambient temperatures of -20°F (-28.9°C).

### High Ambient Option

High ambient option consists of special control logic, compressor motors, and variable speed drives to permit high ambient (up to 125°F [51°C]) operation. Low side ambient remains 32°F (0°C).

### Wide Ambient Option

The wide ambient option combines the features of low and high ambient options for an ambient range of 0° to 125°F (-17.7 to 51°C).

## Electrical Options

### Circuit Breaker

A HACR rated molded case capacity circuit breaker (UL approved) is available. Circuit breaker can also be used to disconnect chiller from main power with a through-the-door handle.

### Harmonic Attenuation

Harmonic attenuation to comply with IEEE 519 and achieving 5% TDD when ISC/ILOAD < 20. (Reference IEEE-519-2014, table 2.) It is important to recognize that IEEE 519 as a guideline relates to the entire system, not specifically to any one load or product. IEEE 519 establishes requirements at the point of common coupling (PCC) where the building connects to the utility system. The standard contains no specific requirements for the internal electrical loads. Even though Trane AFD-equipped chillers will attenuate their own harmonics, other nonlinear loads on the same system could still create harmonic problems. In buildings where harmonics might be a concern, Trane recommends conducting a power-distribution system analysis to determine if there is a need to further attenuate harmonics at the system level.

## Control Options

### BACnet Communications Interface

Allows the user to easily interface with BACnet® via a single twisted pair wiring to a factory installed and tested communication board.



## Options

---

### **LonTalk (LCI-C) Communications Interface**

Provides the LONMARK® chiller profile inputs/outputs for use with a generic building automation system via a single twisted pair wiring to a factory installed and tested communication board.

### **ModBus Communications Interface**

Allows the user to easily interface with ModBus™ via a single twisted pair wiring to a factory installed and tested communication board.

### **Remote Input Options**

Option permits remote chilled liquid setpoint, remote demand limit setpoint, or both by accepting a 4-20 mA or 2-10 Vdc analog signal.

### **Remote Output Options**

Permits alarm relay outputs, chiller Percent Capacity via a 2–10VDC signal, or both.

### **Tracer Communication Interface**

Interface permits bi-directional communication to Tracer® SC or ES system via BACnet® interface.

## **Sound Options**

### **InvisiSound Standard Unit**

Each rotary screw compressor will have a muffler as standard and each condenser fan will be low noise as standard.

### **InvisiSound Superior Unit**

In addition to the sound reducing features on the standard unit, Superior adds insulating sound material to the suction and discharge lines of each refrigerant circuit and reduces the maximum speed of the each condenser fan.

### **InvisiSound Ultimate Unit**

In addition to the sound reducing features on the Superior, the Ultimate unit adds a flexible, metallic connection at the suction and discharge of each compressor, a pre-formed 'sound box' encapsulating each compressor and the ability for the user to set fan speed based on sound requirements. The fan speed can be set for sound reduction from 100% - 60% of maximum fan speed.

## **Other Options**

### **Architectural Louvered Panels**

Louvered panels cover the complete condensing coil and service area beneath the condenser.

### **Condenser Corrosion Protection**

CompleteCoat™ is available on all size units for corrosion protection. Job site conditions should be considered to determine the need to order coating to inhibit coil corrosion and ensure extended equipment life. CompleteCoat™ option provides fully assembled coils with a flexible dip and bake epoxy coating.

### **Convenience Outlet**

Provides a 15 amp, 115V (60 Hz) convenience outlet on the unit.



---

### **Flanged Water Connection Kit**

Provides raised face flanges to convert grooved pipe evaporator water connections to flange connectors.

### **Insulation for High Humidity**

The evaporator is covered with factory-installed 1.25 inch (31.8 mm) Armaflex II or equal (k=0.28) insulation.

### **Isolators — Elastomeric**

Elastomeric Isolators provide isolation between chiller and structure to help eliminate vibration transmission. Elastomeric isolators are required with the InvisiSound™ Ultimate option.



Notes

---





Ingersoll Rand (NYSE: IR) advances the quality of life by creating comfortable, sustainable and efficient environments. Our people and our family of brands – including Club Car®, Ingersoll Rand®, Thermo King® and Trane® – work together to enhance the quality and comfort of air in homes and buildings; transport and protect food and perishables; and increase industrial productivity and efficiency. We are a global business committed to a world of sustainable progress and enduring results.



[ingersollrand.com](http://ingersollrand.com)



The AHRI Certified mark indicates Ingersoll Rand participation in the AHRI Certification program. For verification of individual certified products, go to [www.ahridirectory.org](http://www.ahridirectory.org).

Ingersoll Rand has a policy of continuous product and product data improvements and reserves the right to change design and specifications without notice.  
We are committed to using environmentally conscious print practices.